

Evolutis

CREATEUR FABRICANT



Captiv
Freeliner®



Surgical Technique
Conventional Set

Evolutis
MOTION INSIDE

TABLE OF CONTENTS

Indications and contra-indications	3
Preoperative templating	4
Dimensional correspondence of the cup	5
Reaming of the acetabulum	5
Checking the reaming of the acetabulum with the trial cup	6
Reduction and trials in the trial cup	6
Positioning of the definitive cup	7
<i>With the straight impaction handle</i>	7
<i>With the curved impaction handle</i>	8
Complementary fixation with acetabular screws	9
Trials in the definitive cup	10
Positioning the definitive insert	11
<i>Steps for a ceramic insert</i>	11
<i>Steps for a PEXEL-E insert</i>	12
<i>Steps for a PEXEL insert</i>	12
Femoral head length trials on definitive implants	13
Reduction and wound closure	13
Removal of the ceramic insert	13
Snapshot of the instrumentation set	14
Implant and Instrument references	16

Disclaimer

This document is intended to be read only by experienced orthopaedic surgeons familiar with the application of hip arthroplasty, and by individuals related to or acknowledged by the Evolutis company.

This technical booklet is intended as the recommended procedure for implanting the Evolutis FREELINER® Hip Acetabular System when used in combination with a femoral implant manufactured and supplied by EVOLUTIS. It offers guidance only.

EVOLUTIS is the manufacturer of the device. As such and having no medical expertise, EVOLUTIS does not recommend a specific use of a product or a technique. The surgeon is sole responsible for considering the particular needs of each patient and make appropriate adjustments where necessary. For any additional information related to the products, the indications and contra indications, the warnings and precautions of use, and the adverse effects, please refer to the INSTRUCTION FOR USE leaflet included in the packaging of each implant. For further advice please contact your local EVOLUTIS representative.

Copyrights: no part of this document may be reproduced in whole or part by any process, nor may any other exclusive right be exercised without express permission of the EVOLUTIS company.

Indications and contra-indications

Hemi and total hip arthroplasties are indicated for the treatment of symptomatic pain and/or functional problems of the hip in patients whose skeleton is mature and only when pain killer medication and correctly followed conservative treatment have failed. For the patient, his anatomy and the structure of his articulation will need to be adapted to receive the selected implant(s).

The indications for total or partial hip arthroplasty are:

- Degenerative non inflammatory hip disease (coxarthrosis, arthritis of the hip).
- Inflammatory hip disease (rheumatoid arthritis, post traumatic arthritis).
- Metabolic hip disease (chondrocalcinosis).
- Post Traumatic degenerative arthritis.
- Avascular necrosis.
- Congenital dysplasia of the hip.
- Functional repair of a recent trauma (fracture, dislocation)
- Revision of a failed conservative surgery, osteosynthesis, partial or total arthroplasty.
- Tumoral surgery when affecting the hip joint.



In primary surgery of the hip joint, and even more in revision or tumoral surgery, the quality of the bone stock and the bone defects due to the ablation of any previously implanted material can compromise the primary fixation of the implantable device and thus limit its indications. Depending on the location and the extension of the bone defect, a longer cemented or cementless femoral component including a variety of complementary fixation means or an acetabular component including peripheral flanges and hooks can be considered.

The arthroplasty of the hip can be contra-indicated in cases of local or systemic infection, mental deficiency, neuromuscular afflictions, neurologic or vascular affections, patients addicted to alcohol or psychotropic drugs, excessive medication, excessive functional use (sport with prevalent risk of fall or with excessive functional expectations beyond the limits of the mechanical resistance of the prosthesis), overweight, insufficient bone stock, weak demineralized bone impeding a good prosthetic fixation, or severe extra articular deformation.

Preoperative templating

A set of Captiv FREELINER® templates is available with the instrument set. The set contains two templates:

- Template n°1 for sizes 44 to 54
 - Template n°2 for sizes 56 to 66
- (Please note that sizes 44 and 66 are only available on special request.)

The aim of the pre-operative planning is to predetermine the diameter of the cup best suited for the acetabular cavity and to quantify the relative position of the cup in respect to the femoral component.

Important prerequisite:

The true magnification ratio of the preoperative images need to be checked with the radiologist, and the theater staff should make sure that the templates of the corresponding magnification is available for the surgery. The radiological protocol must be strictly established and known by all the manipulators of the medical imaging department.

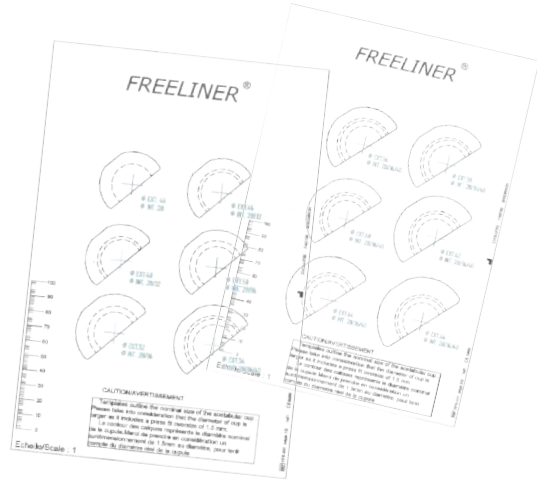

The templating steps are:

- On a frontal x-ray for which the scale has been predetermined trace a horizontal line linking the radiological U in order to check any length discrepancy or abnormality which should be taken into account (fig A)
- Trace a 45° line from the U joining the supero-lateral edge to the acetabular rim (fig B)
- Position the most size suited template to the acetabular in order to (fig C):
 - stay parallel to the traced 45°
 - adapt the circumference of the cup to the geometry of the acetabulum
 - place the bottom of the cup on the quadrilateral blade
- Trace the rotation center of the cup implant and evaluate in terms of shortening and medialization in respect to the center of the anatomic acetabulum
- Template the femoral side juxta positioning the center of the head implant with the center of the cup implant
- Memorize the sizes of the templated implants of the most favorable offset and length.

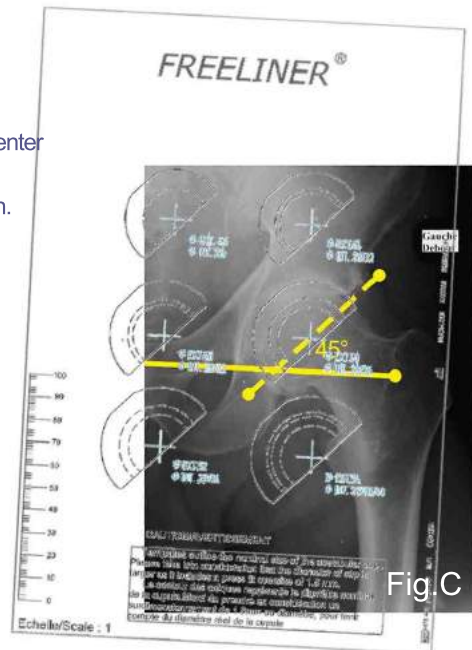
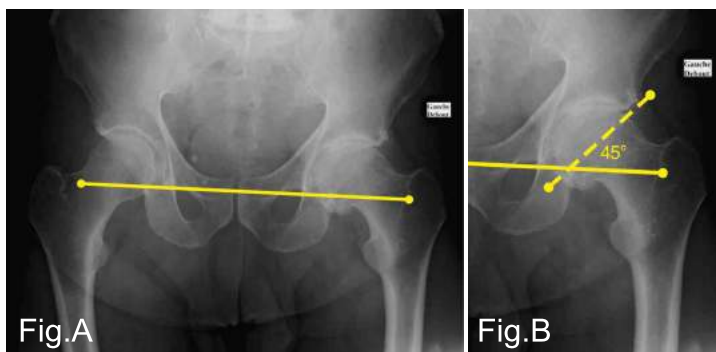

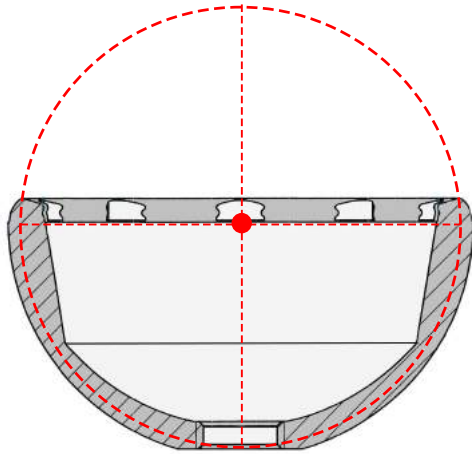

Dimensional correspondence of the cup

Note concerning sizes:

The external geometry of the Captiv FREELINER® cup is hemispherical. The primary stability of the cup is insured by the rugosity of the macro-porous coating and by the peripheral oversize of the cup in comparison to its nominal diameter.

The total oversize is of 1.66mm in the diameter (1.26mm for the cup Ø44, and 1.46mm for the cup Ø46).

Nominal Ø Cup: d → True Ø cup: $d + 1.66\text{mm}$



Reamer Ød

=



Cup Ød

Correspondence between the reamer and the cup size:

The true diameter of the cup must always be larger than the diameter of the last acetabular reamer introduced in order to ensure a good primary fixation and stability of the implant.

This difference in diameter has been taken into account in the cup sizing and description of the Captiv FREELINER®. For most indications, after reaming the acetabulum to a given diameter d , the cup size to be selected will also correspond to d (size for size).

Special cases:

In sclerotic bone, after reaming of the acetabulum to a diameter of d , the Captiv FREELINER® cup could be difficult to position or may seat imperfectly into the acetabulum. In such cases the cup should be removed and either:

- if the anterior and posterior walls of the acetabulum still have enough thickness, introduce an acetabular reamer of diameter $d+2\text{mm}$ only at the entry of the acetabulum and ream the acetabular rim only, or
- if the bone stock allows, deepen the acetabulum with the last reamer introduced without increasing the reaming diameter, and then re-introduce and impact the cup.

Reaming of the acetabulum

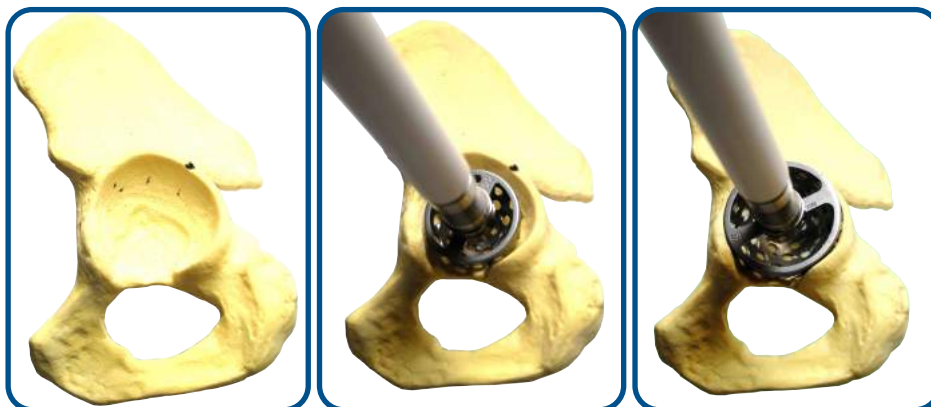

After exposure of the coxo-femoral joint, dislocation of the femoral head, resection of the femoral head, and excision of the labrum and of the residues of the ligamentum teres, begin the reaming of the acetabulum with the smaller size reamer available.

Increment the sizes of reamer down to the sub-chondral bone while avoiding reducing the thickness of the anterior and posterior walls of the acetabulum.

Checking the reaming of the acetabulum with the trial cup

Select a trial cup (ref H03 0446 to H03 0464) corresponding to the size of the last reamer used.

Reamer $\varnothing d =$ Trial cup $\varnothing d$

Screw the trial cup on the straight impaction handle (H76 009) or on the curved impaction handle (H76 001, H76 002 and H76 003) according to the version of your instrumentation set.



Introduce and hammer the setup in the acetabulum in order to evaluate:

- the correct cup size,
- the depth of the reamed cavity,
- the primary stability of the final cup.

Reduction and trials in the trial cup

If the femoral preparation step has already been made, it is possible at this step to proceed to a trial.

Unscrew the impaction handle (straight or curved) out of the trial cup.

Select the trial insert (choice of flat rim or with posterior wall) normally stored with the trial cup in the instrument tray, or that of the same color.



The trial inserts $\varnothing 28\text{mm}$ (with posterior wall), $\varnothing 32\text{mm}$ and $\varnothing 36\text{mm}$ (flat rim) are supplied in standard in the Captiv FREELINER® instrumentation set.
The trial liners $\varnothing 40\text{mm}$ (flat rim) are not supplied in standard and should be requested to your local distributor when necessary.

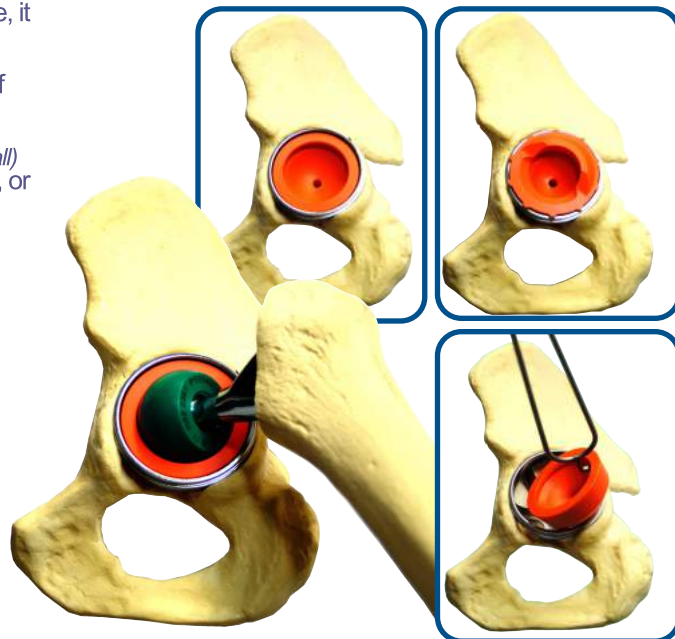

Place the trial liner by hand into the trial cup.

Make sure that the diameter of the trial head is of the same diameter as that of the trial liner. Reduce the hip joint and check for stability and limb length.

After the trials, remove the trial liner with the "hook" side of the drilling guide (H76 010).



Positioning of the definitive cup With the straight impaction handle

Prepare the 45° version axis (H76 019) with the straight impaction handle (H76 009):



- introduce the ring of the 45° axis on the long and narrow cylindrical segment of the impaction handle,
- check that the tip of the 45° is oriented towards the blue grip,
- pull the 45° axis towards the blue grip until it is tightly fixed on the cylindrical and rough segment of the impaction handle.

Open the sterile packaging of the cup, remove the pouches, and leave the cup in the white foam pack.

Introduce the tip of the straight impaction handle into the cup, then screw the impaction handle into the threaded apex hole of the cup. Lock firmly.

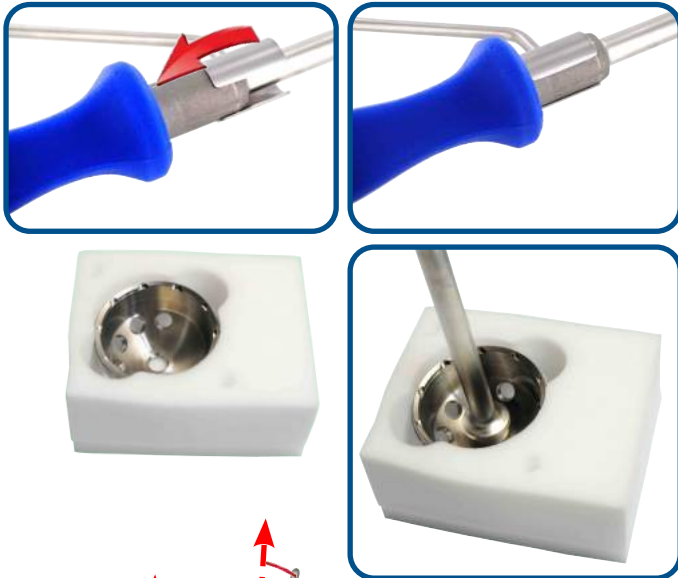

Turn the 45° version axis up so that it is aligned with the superior quadrant of the cup and the 4 screw holes.

Position the cup into the acetabulum.

Check that the 45° version axis is perfectly vertical, and that the impaction handle is orientated with an angle of 15 to 20° from the longitudinal side of the table.

Verticalization (>45°) of the cup is strictly forbidden.

Once the impaction handle is correctly aligned, hammer strongly on the top of the impaction handle to impact the cup.

Check visually the position of the cup through the screw holes of the cup: the convexity of the cup should be flushed with the bottom of the acetabulum.

Check that the anterior edge of the cup is not overflowing and does not present risk of conflict with the tendon of the psoas.

Unscrew and remove the impaction handle.

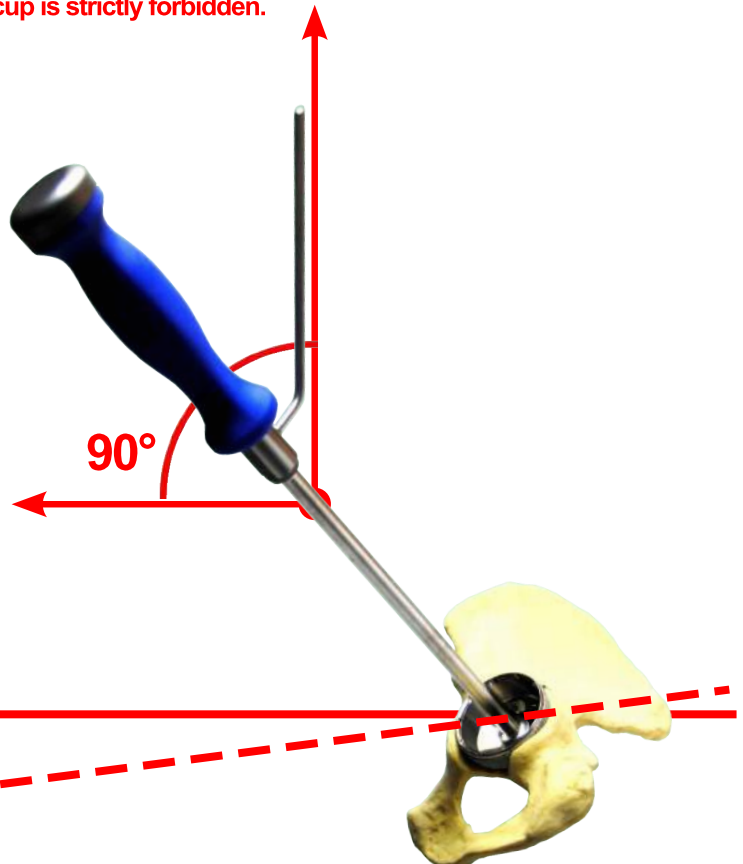
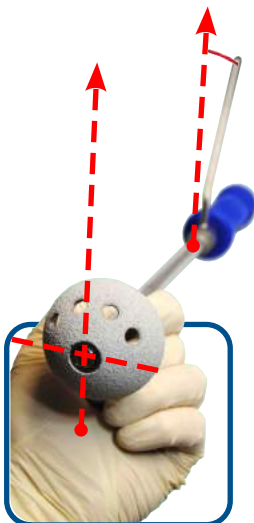

Positioning of the definitive cup With the curved impaction handle

Prepare the screw for curved impaction handle (H76 002) together with its washer, at the extremity of the curved impaction handle (H76 001).
Introduce the screw until its threaded extremity is freed out of the impaction handle.



Introduce the 45° version axis (H76 019) on its dedicated rectangular section on the curved impaction handle, close to the lower part of the blue grip:

- first introduce the ring tip of the 45° version axis on the thinner side of the quadrangular section,
- push the ring tip entirely on the quadrangular section,
- rotate the 45° axis through a quarter turn (90°) until locked on the curved impaction handle.



Introduce the screwdriver with lugs (H76 003) into the upper opening of the curved impaction handle, and then into the head of the screw (H76 002).

Open the sterile packaging of the cup, remove the pouches, and leave the cup in the white foam pack.

Place the tip of the curved impaction handle into the cup, then tighten the screw (H76 002) into the threaded apex hole of the cup.
Lock firmly.

Turn the 45° version axis up so that it is aligned with the superior quadrant of the cup and with the 4 screw holes.

Introduce the cup into the acetabulum.

Check that the 45° version axis is perfectly vertical, and that the impaction handle is orientated with an angle of 15 to 20° from the longitudinal side of the table.

Verticalization (>45°) of the cup is strictly forbidden.

Once the impaction handle is correctly aligned, hammer strongly on the top of the impaction handle to impact the cup.

Check visually the position of the cup through the screw holes of the cup: the convexity of the cup should be flushed with the bottom of the acetabulum.
Check that the anterior edge of the cup is not overflowing and does not present risk of conflict with the tendon of the psoas.

Unscrew the screw with the screwdriver with lugs (H76 003) and remove the curved impaction handle.

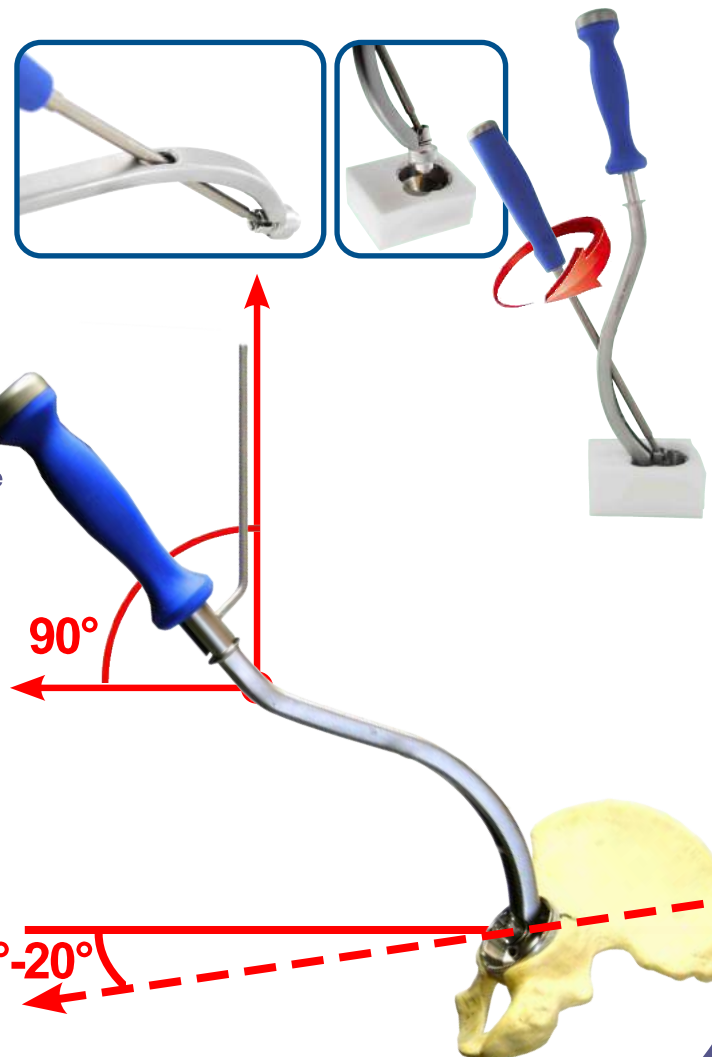

Complementary fixation with acetabular screws

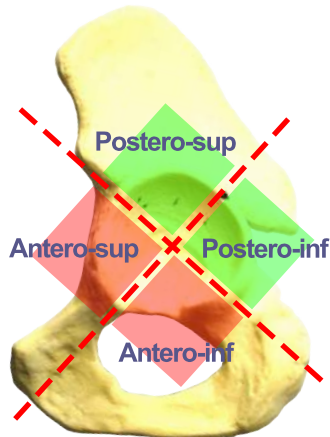

If the primary fixation of the cup does not appear to be satisfactory after impaction, a complementary fixation with up to 4 cancellous screws is possible.

The complementary fixation screws should only be positioned in the posterior quadrants of the acetabulum. The anterior quadrants of the acetabulum should be avoided in standard primary THA cases.

Prepare each screw with the L.25mm (S01 010) or L.45mm (S01 003) drill bit fitted on the flexible shaft for drill (H0010050099), and with the drill guide (H76 010).

Note : The lengths of the drill bits are calculated to include the length of the drill guide. In cases where the drill bit is not long enough for a bi-cortical drilling, and once the first oriented drill hole has been made, remove the drill guide and continue drilling directly with the drill bit alone. This allows for an additional drilling of 15mm.

Measure the length of the screw with the screw gauge (H03 004).

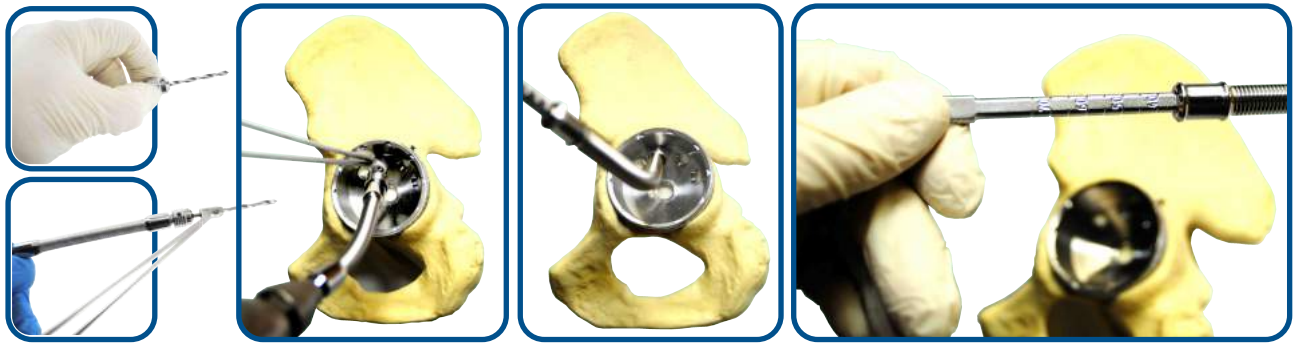

Introduce each screw with the H3.5 screwdriver (S01 005) and with the forceps for screws (H03 003).

Check with the finger that the head of the screw is flush with the concavity of the cup and will not interfere with the seating of the insert. Any such interference could jeopardize the fixation of the ceramic liner and its integrity. In such cases the screw should be tighten again or removed and introduced in another angular direction.



Trials in the definitive cup

Select the trial insert corresponding to the size of the implanted cup.

The posterior wall trial inserts for Ø28mm femoral head and the flat rim trial inserts for Ø32mm & Ø36mm femoral head are delivered in standard with the Captiv FREELINER® instrument sets.

The flat rim trial inserts for Ø40mm femoral head are available on option. Please refer to your local retailer.

Captiv FREELINER® cups and instrumentation are color coded in order to facilitate and secure the choice of the trial components and the selection of the definitive implants.

Example: if the cup implanted is a size 52, high-lighted **blue** on the packaging label, the corresponding trial insert will also be **blue** and so will be the highlight on the cup packaging label.



The trial inserts Ø28mm (with posterior wall), Ø32mm and Ø36mm (flat rim) are supplied in standard in the Captiv FREELINER® instrumentation set.
The trial liners Ø40mm (flat rim) are not supplied in standard and should be requested to your local distributor when necessary.



Labels for a Captiv FREELINER® cup and liners in Ø52



Place a trial insert in the cup.
Reduce the articulation and check the limb length and the stability.



To remove the trial insert use the 'hook' side of instrument H76 010.

Positioning of the definitive insert Steps for a ceramic insert



Select the definitive insert by means of the color code on the packaging label. The color code must be the same that the one on the packaging of the cup.

Open the sterile packaging keeping the insert in the packaging foam.

Position the insert sucker (H30 002) in the ceramic insert.



Push the sucker in order to achieve a vacuum fixing it to the insert.

Handle the setup with care in order to avoid the sucker coming off releasing the ceramic insert and falling off.

Carefully clean and dry the inside of the cup.

Introduce the insert into the cup. Check visually and by fingering that the insert is correctly orientated in the taper of the cup. Any misdirection of the insert in the cup during its introduction can jeopardize its fixation into the cup and compromise the resistance of the ceramic at the impaction step or during the functional loading in the post-operative use. In the cases where the insert is badly orientated, refer to the removal procedure described in page 13 (Removal of the ceramic insert).

Slightly and gently impact on the extremity of the sucker.

Release the sucker in the insert by pulling on the trigger freeing the vacuum.



Affix the corresponding spherical impactation nozzle (H76 004 à H76 007) of the same diameter as the insert (Ø28, Ø32 or Ø36 if standard, Ø40 on option) on the straight impactation handle (H76 009) or on the curved impactation handle (H76 001, H76 002 and H76 003) according to your instrument set, and drive home the ceramic insert with a sharp hammer blow on the impactation handle.



Steps for a PEXEL-E insert Ø32 ou 36 with flat rim

Select the definitive highly crosslinked with E vitamin insert by means of the color code on the packaging label.
The color code should be identical to that of the cup.

Open the sterile packaging keeping the insert in the packaging foam.

Carefully clean and dry the inside of the cup.

Introduce by hand the insert into the cup checking that the spigots on the insert are correctly aligned with the crenels on the cup.
The PEXEL-E inserts are only available with flat rim. The insertion of the insert require no specific orientation.



Affix the corresponding spherical impactation nozzle (H76 004 à H76 007) of the same diameter as the insert (Ø28, Ø32 & Ø36 standard, Ø40 on option) on the straight impactation handle (H76 009) or on the curved impactation handle (H76 001, H76 002 and H76 003) according to your instrument set.

Position the insert into the cup and check that the spigots of the insert are correctly aligned with the crenels on the cup.

Check visually that the insert is correctly aligned with the peripheral edge of the cup, then position the impactor into the insert and finalize the impactation of the insert with a sharp hammer blow.
Check visually the correct positioning of the spigots into the crenels of the cup, and that there is no micro-mobility between the insert and the cup.

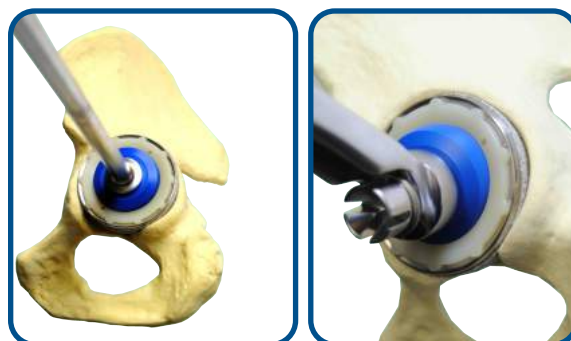

Steps for a PEXEL insert Ø28 with posterior wall

Select the definitive UHMWPE insert by means of the color code on the packaging label.

The color code must be the same that the one on the packaging of the cup.

Open the sterile packaging keeping the insert in the packaging foam.

Carefully clean and dry the inside of the cup.

Prepare the impactation plate for Ø28 insert (H76 028) and the spherical Ø28mm impactation nozzle (H76 004) on the straight impactation handle (H76 009) or on the curved impactation handle (H76 001, H76 002 and H76 003) according to your instrument set, and then position the plate and tip directly on the Ø28 posterior wall insert.
Make sure that the 2 spurs of the impactation plate are correctly aligned with the 2 holes on the insert. The beveled plan of the impactation plate should match the posterior wall profile of the insert.

Position the insert into the cup and check that the posterior wall of the insert is orientated in the postero-superior quadrant of the acetabulum, and that the spigots on the insert are correctly aligned with the crenels on the cup.

Check visually that the insert is correctly aligned with the peripheral edge of the cup, then finalize the impactation of the liner with a sharp hammer blow.

Check visually the correct positioning of the spigots into the crenels of the cup, and that there is no micro-mobility between the insert and the cup.



Femoral head length trials on definitive implants

After positioning of the definitive femoral stem, achieve a final femoral head trials:
Place a femoral head trial (*instrumentation of the femoral implant*) corresponding to the inner diameter of the Captiv FREELINER® insert.

Reduce the joint and test for stability and limb length.
If necessary change the length of the femoral head trial until the proper stability and length is achieved.

Position the definitive femoral head of the length and diameter corresponding to the best femoral head trial used.

Note: the PEXEL & PEXEL-E inserts can be used in association either with a metal (*stainless steel or cobalt-chromium*) or a ceramic femoral head. The ceramic inserts can only be used in association with a ceramic femoral head.

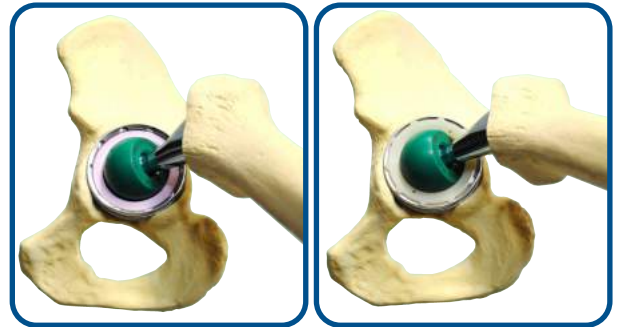

Reduction and wound closure

Reduce the articulation.
Clean the wound extensively.
Close and suture the capsule.
Suture the muscle, subcutaneous and dermal layers.

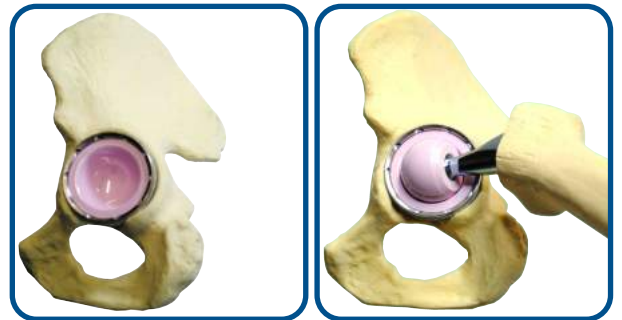

Removal of the ceramic insert

In the case of a cup revision the first thing to do is to remove the ceramic insert before being able to unscrew any complementary fixation screw and introduce an impaction handle in the apex hole of the cup.

Clean and dry the ceramic insert.
Place the sucker in the ceramic insert.
Press down the sucker so as to create a vacuum.



Use the insert extractor (*H30 001*) and place it on the external rim of the cup.
While maintaining traction on the sucker handle give a sharp hammer blow on the insert extractor.
If necessary repeat the operation until the insert is freed.

Remove the ceramic insert.

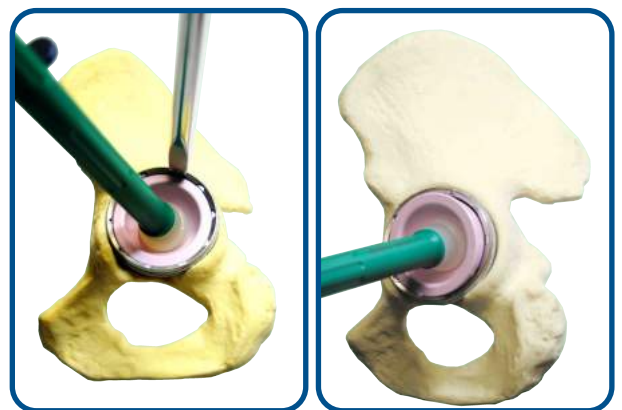

Instrumentation SNAPSHOT

Ref : H76 9100 FREELINER manche droit / straight

Dec 2015 / Ref: BL_FREELINER Straight SNP H76 9100

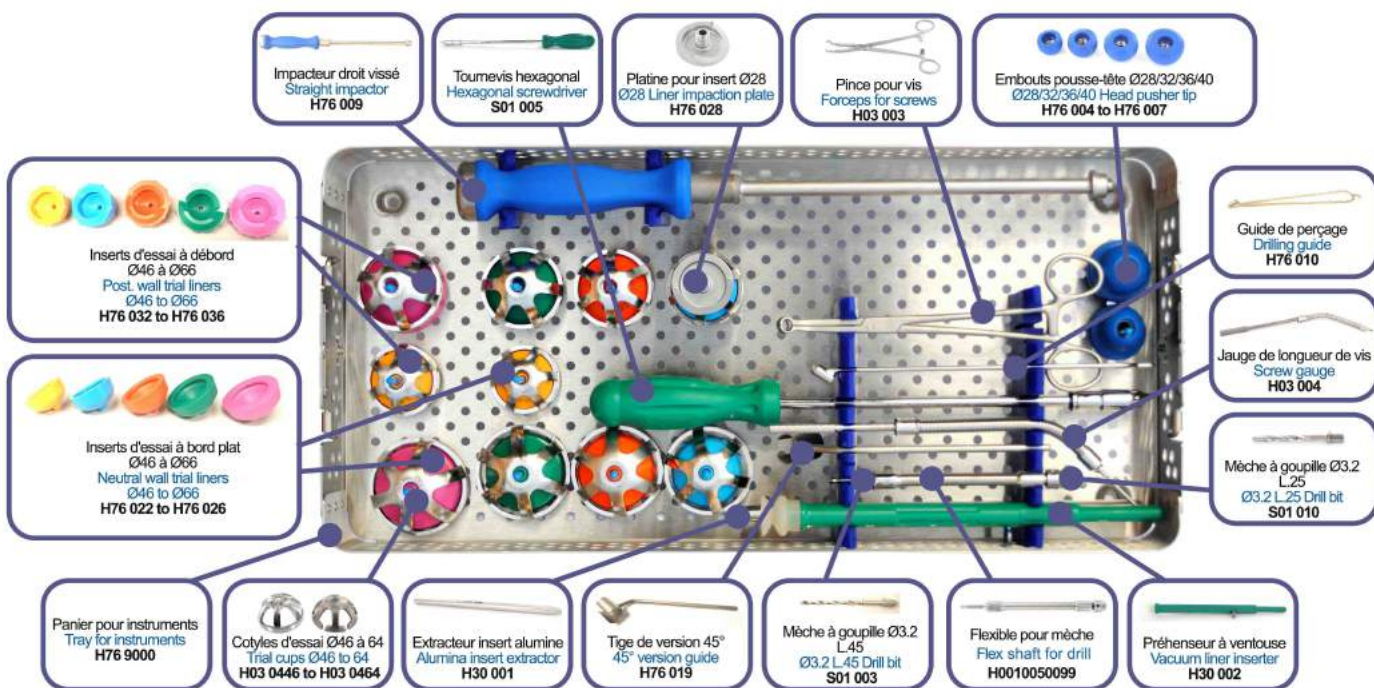

www.evolutisfrance.com / Evolutis, Avenue de la Libération, 42720 Briennon, France. Tel : +33. (0)477.60.79.99 – Fax : +33. (0)477.60.79.90

Instrumentation SNAPSHOT

Ref: H76 9101 FREELINER manche courbe / curved

Dec 2015 / Ref: BL_FREELINER Curved SNP H76 9101

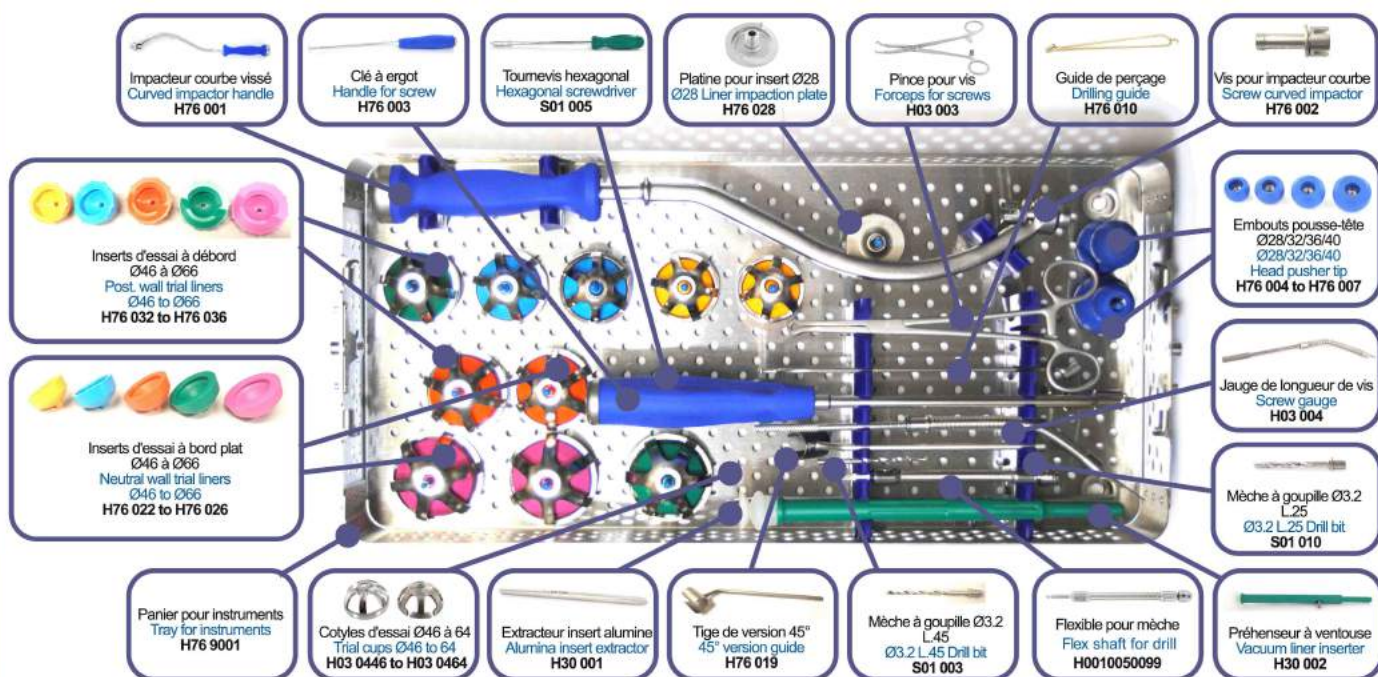

www.evolutisfrance.com / Evolutis, Avenue de la Libération, 42720 Briennon, France. Tel : +33. (0)477.60.79.99 – Fax : +33. (0)477.60.79.90

Notes :

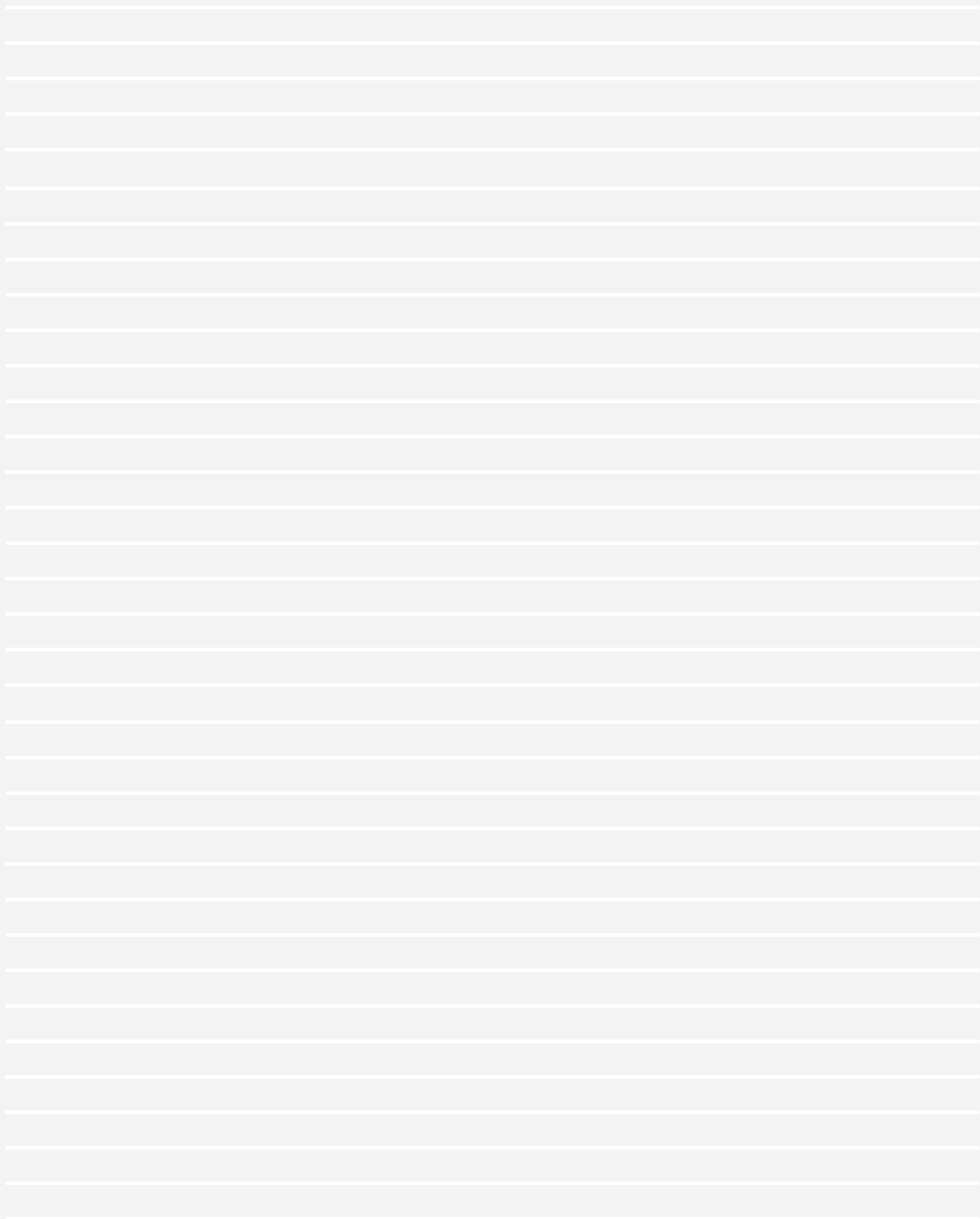

A series of horizontal white lines for writing, starting below the 'Notes :' label and extending to the bottom of the page. The lines are evenly spaced and cover the entire width of the page.

Captiv Freeliner®

Ref. Cup.	Ref. Liner					
	Ø28 UHMWPE "PEXEL"	Ø32 XLPE "PEXEL-E"	Ø36	Ø32	Ø36	Ø40 CERAMIC
Ø44 (*)	H75 4438(*)	H75 P3828(*)				
Ø46	H75 4640	H75 P4028		H75 XE4032		H75 C4032
Ø48	H75 4840	H75 P4428		H75 XE4432		H75 C4436
Ø50	H75 5044	H75 P4828		H75 XE4832		H75 C4836 H75 C4840
Ø52	H75 5244	H75 P5028		H75 XE5032(*)		H75 C5036 H75 C5040
Ø54	H75 5448	H75 P5428		H75 XE5432(*)		H75 C5436 H75 C5440
Ø56	H75 5648	H75 P6050		H75 XE6050		
Ø58	H75 5850	H75 P6254		H75 XE6254		
Ø60	H75 6050	H75 P6454		H75 XE6454		
Ø62	H75 6254	H75 P6654(*)		H75 XE6654(*)		
Ø64	H75 6454					
Ø66 (*)	H75 6654(*)					



A colour code (red, yellow, blue, orange, green, pink) facilitates the cup and liner size match. Example for a 58mm cup, the colour code is "green": once the material and the inner diameter are selected, choose the corresponding liner along the green line.

Acetabular screw / vis à cotyle

	Length Longueur	Ref.
Ø6.0 Screw/Vis	20 mm	H15 SB6020
Ø6.0 Screw/Vis	25 mm	H15 SB6025
Ø6.0 Screw/Vis	30 mm	H15 SB6030
Ø6.0 Screw/Vis	35 mm	H15 SB6035
Ø6.0 Screw/Vis	40 mm	H15 SB6040
Ø6.0 Screw/Vis	45 mm	H15 SB6045
Ø6.0 Screw/Vis	50 mm	H15 SB6050



Material
Cup: TA6V titanium alloy according ISO 5832-3, Porous titanium and Calcium hydroxyapatite coating
Screw: TA6V titanium alloy according ISO 5832-3
Liner: UHMWPE according ISO 5834-1 and 2, or Composite Ceramic according ISO 6474-2
Packaging: vacuum packed and gamma ray sterilized



Designed and
Manufactured in
France

www.evolutisfrance.com

CE Evolutis

Avenue de la Libération, 42720 Briennon, France
0499 Tel : +33. (0)477.60.79.99 – Fax : +33. (0)477.60.79.90

Your EVOLUTIS retailer is:

(*): References available only on special request